

COMPACT 620 MM  
BY 420 MM TUNNEL  
CHECKPOINT  
SCREENING SYSTEM  
FOR CRITICAL  
INFRASTRUCTURE  
PROTECTION,  
HOTELS, AND  
PRISONS

SUPERB IMAGE QUALITY

HIGHLY RELIABLE

SMALL FOOTPRINT

#### STANDARD FEATURES

- Multi Energy Imaging (4 Color)
- View Previous/Next Bag
- Image Archive
- Configurable Image Processing Keys
- Baggage Counter
- Date / Time Display
- Search Indicator
- Flat Panel Monitor

#### STANDARD IMAGE PROCESSING FUNCTIONS

- Crystal Clear™
- SINERGY™
- Black and White
- Organic / Inorganic Stripping
- Inverse Video
- High Penetration
- Low Penetration
- Pseudo Color
- Variable Edge Enhancement
- Variable Color Stripping
- Variable Gamma
- Variable Density
- Dynamic Continuous Zoom & Panning
- Fixed Zoom (64x)

[sales@rapiscansystems.com](mailto:sales@rapiscansystems.com)  
[www.rapiscansystems.com](http://www.rapiscansystems.com)

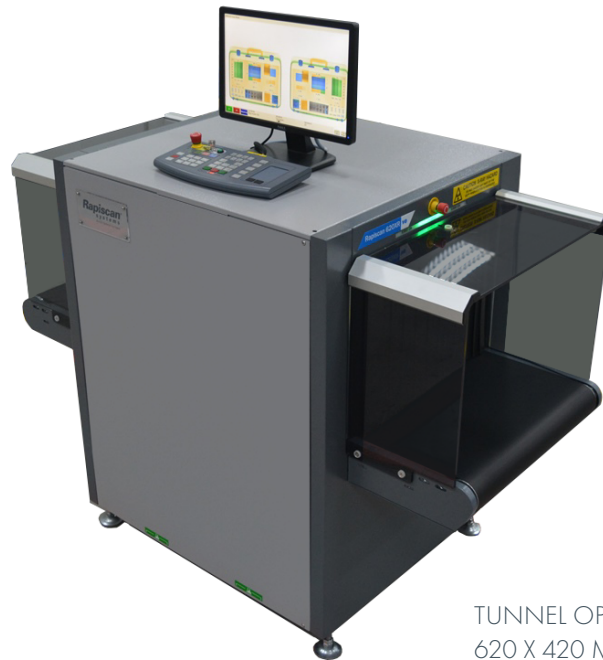

TUNNEL OPENING (W X H):  
620 X 420 MM (24.4 X 16.5 IN)

THE NEW RAPISCAN 620XR ve IS A DUAL MODE, DUAL ENERGY 620 MM BY 420 MM TUNNEL X-RAY SECURITY SCREENING SYSTEM WITH EXCELLENT WIRE RESOLUTION PERFORMANCE.

The 620XR ve utilizes a 140kV X-ray generator and implements Rapiscan's proprietary dual energy imaging technique allowing the system to extract information about the object's atomic composition and material discrimination, resulting in superior image quality.

The Rapiscan 620XR ve is ideal for critical infrastructure security that includes government buildings, utilities, landmarks, prisons, and hotels.

#### EASE OF USE PROVIDING HIGHEST THROUGHPUT

With over 14 image processing tools, the feature-rich software allows the operator to more easily and accurately search for contraband.

#### SINERGY™

Rapiscan's latest proprietary image enhancement tool, utilizes the new innovative Dual-Mode X-ray imaging Technique (DMxT) to emphasize the detail in specific regions of images by enhancing the visibility of thin metal therefore increasing operator recognition of potential threats in cluttered images.

# RAPISCAN 620XR ve

**Rapiscan**<sup>®</sup>  
systems

An OSI Systems Company

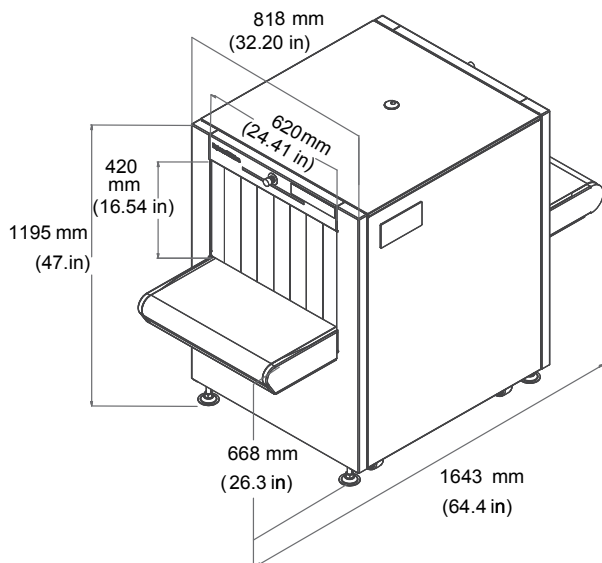

## PHYSICAL SPECIFICATIONS

Dimensions:	Length: 1643 mm (64.4 in.) Width: 818 mm (32.2 in.) Height: 1,195 mm (47 in.)
Tunnel Size:	620 mm (W) x 420 mm (H) (24.4 x 16.5 in.)
Conveyor Speed:	0.20 m/sec (39.4 ft./min)
Conveyor Load (Max):	165 Kg (364 lbs) evenly distributed
Conveyor Height (Approx.):	668 mm (26.3 in.)
Weight (Approx.):	Net: 373 Kg (822.3 lbs) Gross: 482 Kg (1062.6 lbs)
System Power:	115/230 VAC ±10%

## X-RAY GENERATOR AND IMAGE PERFORMANCE<sup>1</sup>

Steel Penetration:	30 mm standard
Wire Resolution:	41 AWG standard
Cooling:	Sealed oil bath with forced air
Anode Voltage:	140kV
Orientation:	Diagonally Upward

## OPERATING ENVIRONMENT

Storage Temperature:	-20°C to 50°C
Operating Temperature:	0°C to 40°C
Relative Humidity:	5 to 95% non-condensing

## PROTECTION CLASS

System:	IP20
Operator Control Panel:	IP43 <sup>2</sup>

## HEALTH & SAFETY

Rapiscan Systems' cabinet X-ray products comply with all applicable U.S. FDA and equivalent international regulatory agency requirements, contained in the cabinet X-ray radiation safety performance standard [21 CFR 1020.40] and the general performance standard [21 CFR Part 1010] as well as IEC standard 61010-2-091.

Rapiscan baggage and parcel inspection systems radiation emission leakages are well below the required regulatory limits with less than 1 µSv/hr at 10 cm from all surfaces of cabinet X-ray.

## SOFTWARE

- OS600
- 64-bit Operating System

## OPTIONS AND ACCESSORIES

- Density Threshold Alert (DTA)
- Threat Image Projection (TIP)
- Automatic Image Archiving
- Operator Training Program (OTP)
- Foot-mat
- Power Conditioner
- Rollerbed Accessories
- Dual Monitor Kit

<sup>1</sup> Stated performance as measured by Rapiscan Imaging Validation Test Kit.

<sup>2</sup> With optional replaceable cover.

With continual development of our products Rapiscan Systems reserves the right to amend specifications without notice. Product pictures are for general reference. Please note that due to US laws and regulations, not all Rapiscan products are available for sale in all countries without restriction. Please contact your Rapiscan Systems sales representative for more information.

## AMERICAS, CARIBBEAN

2805 Columbia Street  
Torrance,  
California  
90503

## UNITED STATES of AMERICA

Tel: +1 310-978-1457  
Fax: +1 310-349-2491

## EUROPE, MIDDLE EAST, AFRICA

X-Ray House  
Bonehurst Road  
Salfords  
Surrey RH1 5GG

## UNITED KINGDOM

Tel: +44 (0) 870-7774301  
Fax: +44 (0) 870-7774302

## ASIA

240 Macpherson Road  
#07-01 Pines Industrial Building  
Singapore  
348574

## SINGAPORE

Tel: +65-6846-3511  
Fax: +65-6743-9915



Rapiscan Systems is ISO 9001:2008 and  
ISO 14001:2004 + Cor. 1:2009 Certified

[sales@rapiscansystems.com](mailto:sales@rapiscansystems.com)  
[www.rapiscansystems.com](http://www.rapiscansystems.com)