

MOBILE HIGH
PERFORMANCE
SECURITY
SCREENING SYSTEM

Large pneumatic wheels
for easy transport

Lockable, pullout operator control
panel and monitor console

Tie-down anchor points

Easy to access cable reel

STANDARD FEATURES

- Multi Energy Imaging (4 Color)
- View Previous/Next Bag
- Image Archive
- Configurable Image Processing Keys
- Baggage Counter
- Date / Time Display
- Search Indicator
- UPS (Uninterrupted Power Supply)
- Flat Panel Monitor
- Multi Language Support

STANDARD IMAGE PROCESSING
FUNCTIONS

- Crystal Clear™
- SINERGY™
- Black and White
- Organic / Inorganic Stripping
- Inverse Video
- High Penetration
- Low Penetration
- Pseudo Color
- Variable Edge Enhancement
- Variable Color Stripping
- Variable Gamma
- Variable Density
- Dynamic Continuous Zoom & Panning
- Fixed Zoom (64x)



INOPERATIVE MODE

TUNNEL OPENING (W X H):
540 X 360 MM (21.3 X 14.2 IN)

THE RAPISCAN[®] MOBILE 618XR hp IS A PORTABLE X-RAY SCREENING SYSTEM WITH A 540MM WIDE BY 360MM HIGH TUNNEL OPENING, FEATURING LARGE SHOCK ABSORBING PNEUMATIC WHEELS FOR EASY TRANSPORTABILITY.

Based on an established legacy of innovation, quality and reliability, the Mobile 618XR hp provides an array of technologies designed to assist the operator in threat detection as well as improve throughput and operations for checkpoint screening applications. The Mobile 618XR hp is designed for rapid relocation and can be wheeled through narrow doorways, making it an excellent system for cruise lines, schools, prisons, and event-based security environments.

DETECTION OF EXPLOSIVES AND NARCOTICS ALERT

Target™ and NARCScan™ are designed to assist operators in the detection of a range of explosives and narcotics respectively in real time during the scanning process by marking a potential threat on the X-ray image. Rapiscan[®] Systems detection algorithms are based on regulatory material analysis techniques.

GOVERNMENT REGULATORY COMPLIANCE

Rapiscan[®] Mobile 618XR hp performance is in full compliance with the mandatory regulations (EC) No. 300/2008, (EU) No. 185/2010 and Commissions Decision C(2010)774 for aviation security in the European Union.

SINERGY™

Rapiscan[®] Systems latest proprietary image enhancement tool, utilizes the new innovative Dual-Mode X-ray imaging Technique (DMxT) to emphasize the detail in specific regions of images by enhancing the visibility of thin metal therefore increasing operator recognition of potential threats in cluttered images.

EFFICIENT DESIGN FOR EASE OF USE, HIGHEST THROUGHPUT AND SECURE

Rapiscan[®] Mobile 618XR hp is supported by a rigid-steel structure, and is equipped with painted handles at its sides and large pneumatic caster wheels at its base for ease of maneuverability.

The wheels enable operators to move the Mobile 618XR hp easily, and offer a locking function to achieve stability and security during use.

A lockable, easy slide out control panel tray and monitor is securely located on top of the system.



MOBILE 618XR hp

Rapiscan®
systems
An OSI Systems Company

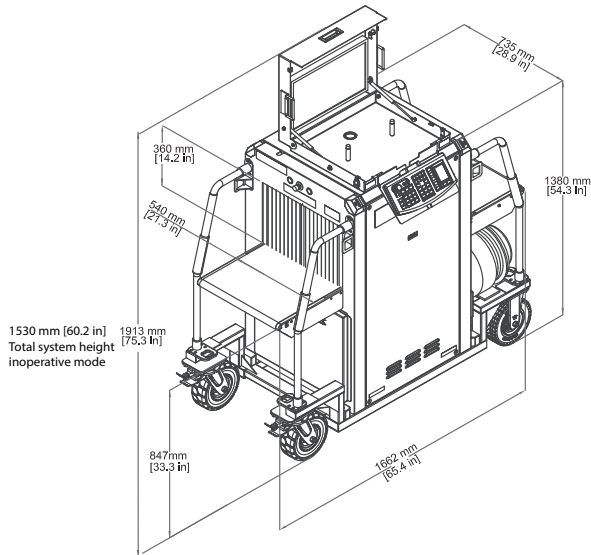

PHYSICAL SPECIFICATIONS

Dimensions:	Length: 1,662 mm (65.4 in.) Width: 735 mm (28.9 in.) Height: 1,913 mm (75.3 in.) open, 1,530 mm (60.2 in.) closed
Tunnel Size:	540 mm (W) x 360 mm (H) (21.3 x 14.2 in.)
Conveyor Speed:	0.20 m/sec (39.4 ft./min)
Conveyor Load (Max):	165 Kg (364 lbs)
Conveyor Height (Approx.):	847 mm (33.3 in.)
System Power:	100/110/120/200/208/220/230/240VAC ±10%

X-RAY GENERATOR AND IMAGE PERFORMANCE¹

Steel Penetration:	33 mm typical, 31 mm standard
Wire Resolution:	40 AWG typical, 38 AWG standard
Spatial Resolution:	0.8mm vertical/ 0.8mm horizontal
Cooling:	Sealed oil bath with forced air
Anode Voltage:	140kV
Orientation:	Diagonally Upward

OPERATING ENVIRONMENT

Storage Temperature:	-20°C to 50°C
Operating Temperature:	0°C to 40°C
Relative Humidity:	5 to 95% non-condensing

PROTECTION CLASS

System:	IP20
Operator Control Panel:	IP43 ²

GOVERNMENT REGULATORY

- Regulation (EC) No. 300/2008 Compliant
- Regulation (EU) No. 185/2010 Compliant
- EU Commissions Decision C(2010)774 Compliant

HEALTH & SAFETY

Rapiscan Systems' cabinet X-ray products comply with all applicable U.S. FDA and equivalent international regulatory agency requirements, contained in the cabinet X-ray radiation safety performance standard [21 CFR 1020.40] and the general performance standard [21 CFR Part 1010] as well as IEC standard 61010-2-091.

Rapiscan baggage and parcel inspection systems radiation emission leakages are well below the required regulatory limits with less than 1µSv/hr at 10 cm from all surfaces of cabinet X-ray.

SOFTWARE

- OS600
- 64-bit Operating System

OPTIONS AND ACCESSORIES

- Explosives Detection Alert (Target™)
- Narcotics Detection Alert (NARCScan™)
- Density Threshold Alert (DTA)
- Threat Image Projection (TIP)
- Automatic Image Archiving
- Enhanced Image Archiving
- Operator Training Program (OTP)
- Manual Scan
- Power Conditioner
- Extended UPS

¹ Stated performance as measured by Rapiscan® Imaging Validation Test Kit.

² With optional replaceable cover.

With continual development of our products Rapiscan® Systems reserves the right to amend specifications without notice. Product pictures are for general reference. Please note that due to US laws and regulations, not all Rapiscan® products are available for sale in all countries without restriction. Please contact your Rapiscan® Systems sales representative for more information.

AMERICAS, CARIBBEAN

2805 Columbia Street
Torrance,
California
90503

UNITED STATES of AMERICA

Tel: +1 310-978-1457
Fax: +1 310-349-2491

EUROPE, MIDDLE EAST, AFRICA

X-Ray House
Bonehurst Road
Salfords
Surrey RH1 5GG

UNITED KINGDOM

Tel: +44 (0) 870-7774301
Fax: +44 (0) 870-7774302

ASIA

240 Macpherson Road
#07-01 Pines Industrial Building
Singapore
348574

SINGAPORE

Tel: +65-6846-3511
Fax: +65-6743-9915



Certified to
AS9100C



Procedy Right.

Rapiscan Systems is AS9100C:2009 and
ISO 14001:2004 + Cor. 1:2009 Certified

sales@rapiscansystems.com
www.rapiscansystems.com