

RAPISCAN 618XR

A versatile, mobile and powerful X-ray inspection system for screening in small spaces.

Versatile Screening System

Compact Design

Portable

Network Enabled

Cost Effective

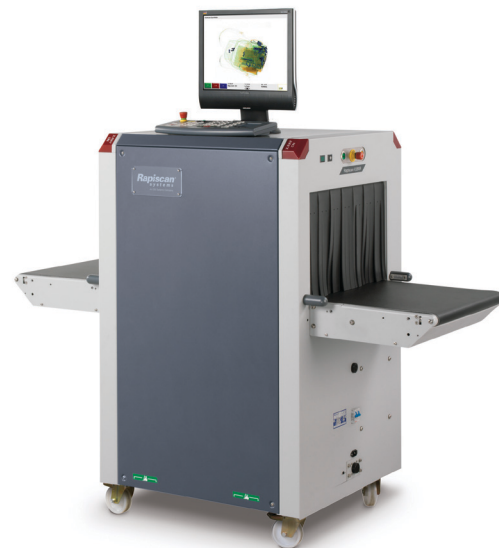

The Rapiscan 618XR is a compact and versatile X-ray screening system with exceptional image quality and excellent detection capabilities. The 618XR is designed for rapid relocation and can be wheeled through narrow doorways, making it an excellent system for schools, hotels, convention centers and event-based security environments.

Like all systems in the 600 series family of X-ray scanning solutions, the Rapiscan 618XR is built on a standardized platform that makes it easy to install and maintain, and comes with features such as dual-energy detection, a streamlined, ergonomic design, and Rapiscan's feature-rich OS600 system software.

Tunnel Opening (width x height):
550 x 360 mm (21.7 x 14.2 in)

Standard Features

- Multi Energy Imaging (4 Color)
- View Previous/Next Bag
- Manual Image Archive
- Configurable Image Processing Keys
- Baggage Counter
- Date / Time Display
- Search Indicator
- UPS (Uninterrupted Power Supply)
- Flat Panel Monitor

Standard Image Processing Functions

- Crystal Clear™
- Black and White
- Organic / Inorganic Stripping
- Inverse Video
- High Penetration
- Pseudo Color
- Low Penetration
- Variable Edge Enhancement
- Variable Color Stripping
- Variable Gamma
- Variable Density
- Dynamic Continuous Zoom & Panning
- Fixed Zoom (64x)

Automatic Detection of Explosives

Target™ automatically detects a wide range of explosives in real time during the scanning process by visibly highlighting a potential threat on the X-ray image.

Automatic Detection of Narcotics

NARCScan™ automatically detects a wide range of narcotics in real time during the scanning process by visibly highlighting a potential threat on the X-ray image.

Greatest Number of Operator-Assist Tools Enables Highest Throughput

With over 13 image processing tools and multiple automatic detection functions, the feature rich software helps the operator easily and accurately detect contraband for the highest throughput and least operator fatigue.

Regulatory Compliance

Rapiscan 618XR image quality performance is in compliance with regulation (EC) No. 300/2008. In addition, Rapiscan 618XR Threat Image Projection (TIP) is in compliance with regulation (EU) No. 185/2010.



Rapiscan[®]
systems
An OSI Systems Company

www.rapiscansystems.com

RAPISCAN 618XR

Physical Specifications

Dimensions:	Length: 1,662 mm (65.4 in.) Width: 735 mm (28.9 in.) Height: 1,366 mm (53.8 in.)
Tunnel Size:	550 mm (W) x 360 mm (H) (21.7 x 14.2 in.)
Conveyor Speed:	0.20 m/sec (39.4 ft./min)
Conveyor Load:	165 Kg (364 lbs) evenly distributed
Conveyor Height:	830 mm (32.7 in.)
Approx Weight:	Net: 425 Kg (937 lbs)
System Power:	115/230 VAC ±10%, 60/50Hz

X-Ray Generator and Image Performance*

Steel Penetration:	28 mm guaranteed; 30 mm typical
Wire Resolution:	38 AWG guaranteed; 40 AWG typical
Material Separation:	Low Z, Medium Z, High Z to 0.5 Z accuracy
Generator Cooling:	Sealed oil bath with forced air
Anode Voltage:	Operating at 140kV
Tube Current:	0.7 mA
Orientation:	Vertically Upward

Operating Environment

Storage Temperature:	-20°C to 50°C
Operating Temperature:	0°C to 40°C
Relative Humidity:	5 to 95% non-condensing

Health & Safety

Rapiscan Systems' cabinet X-ray products comply with all applicable US FDA and equivalent international regulatory agency requirements, contained in the cabinet X-ray radiation safety performance standard [21 CFR 1020.40] and the general performance standard [21 CFR Part 1010]. Rapiscan Systems certifies each cabinet X-ray product has a maximum radiation emission leakage of less than 1 µSv/hr (0.1 mR/hr) from all external surfaces of the cabinet X-ray system.

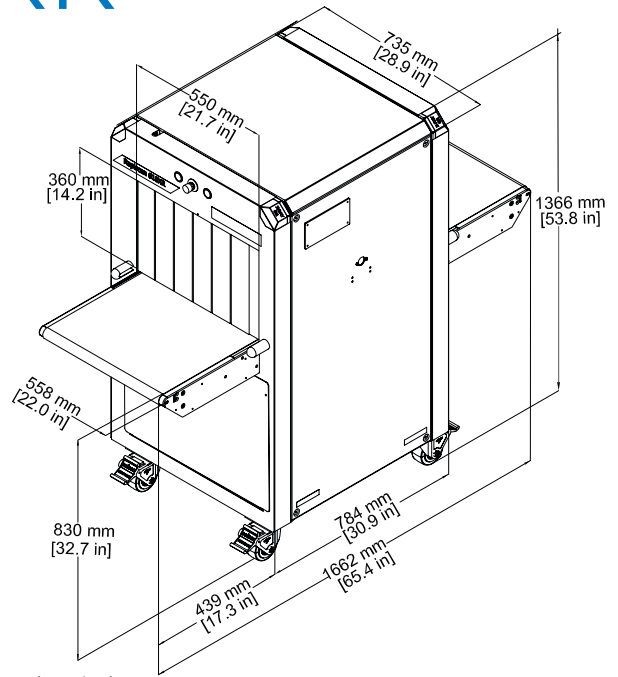

Options and Accessories

Target™ / Interactive Target™ (Automatic detection of solid explosives)	Computer Based Operator Training (CBT)
NARCSan™ (Automatic detection of narcotics)	Operator Training Program (OTP)
Density Threshold Alert (DTA)	Manual Scan
Threat Image Projection (TIP)	Operator Pedestal
Threat Image Projection Network (TIPNet)	Foot-mat
NETView™ (Remote network image archive review)	Optical Operator Presence Sensor
NEXLink™ (Advanced network X-ray management automation and link system)	SmartCard Login
Multi-System Alarm Resolution Network Display Station (NDS)	Power Conditioner
Automatic Image Archiving	Conveyor Accessories
Enhanced Image Archiving	Remote Workstation
	Universal Printer Support

*Stated performance as measured by Rapiscan Imaging Validation Test Kit.

With continual development of our products Rapiscan Systems reserves the right to amend specifications without notice. Product pictures are for general reference. Please note that due to US laws and regulations, not all Rapiscan products are available for sale in all countries without restriction. Please contact your Rapiscan Systems sales representative for more information.

AMERICAS, CARIBBEAN

2805 Columbia Street
Torrance, California 90503
UNITED STATES OF AMERICA
Tel: +1 310-978-1457
Fax: +1 310-349-2491

EUROPE, MIDDLE EAST, AFRICA

X-Ray House
Bonehurst Road
Salfords
Surrey RH1 5GG
UNITED KINGDOM
Tel: +44 (0) 870-7774301
Fax: +44 (0) 870-7774302

ASIA

240 Macpherson Road
#07-01 Pines Industrial Building
Singapore 348574
SINGAPORE
Tel: +65-6846-3511
Fax: +65-6743-9915

EMAIL

sales@rapiscansystems.com

WEB

www.rapiscansystems.com

Rapiscan
systems

An OSI Systems Company



Rapiscan Systems is
ISO 9001:2008 Certified

ONE COMPANY - TOTAL SECURITY

www.rapiscansystems.com