

RAPISCAN 626XR

Efficient X-ray screening for larger baggage and parcels.

Large Baggage and Parcel Screening

Proven Performance for Customs Applications

Compact Footprint

Network Enabled



The Rapiscan 626XR can efficiently screen larger baggage, parcels, packages and irregularly shaped objects for air cargo screening and customs applications. It also features easy loading conveyors and a compact footprint that allows customers to make the most of the available space.

Rapiscan 626XR complies with U.S. Code of Federal Regulations (CFRs) on performance standards for ionizing radiation-emitting products, electronics products, radio frequency devices, qualification of screening personnel, occupational noise exposure and occupational safety and health standards.

Tunnel Opening (width x height):
950 x 650 mm (37.4 x 25.6 in)

Standard Features

- Multi Energy Imaging (4 Color)
- View Previous/Next Bag
- Manual Image Archive
- Configurable Image Processing Keys
- Baggage Counter
- Date / Time Display
- Search Indicator
- UPS (Uninterrupted Power Supply)
- Remote Workstation
- Flat Panel Monitor

Standard Image Processing Functions

- Crystal Clear™
- Black and White
- Organic / Inorganic Stripping
- Inverse Video
- High Penetration
- Pseudo Color
- Low Penetration
- Variable Edge Enhancement
- Variable Color Stripping
- Variable Gamma
- Variable Density
- Dynamic Continuous Zoom & Panning
- Fixed Zoom (64x)

Automatic Detection of Explosives

Target™ automatically detects a wide range of explosives in real time during the scanning process by visibly highlighting a potential threat on the X-ray image.

Automatic Detection of Narcotics

NARCSan™ automatically detects a wide range of narcotics in real time during the scanning process by visibly highlighting a potential threat on the X-ray image.

Greatest Number of Operator-Assist Tools Enables Highest Throughput

With over 13 image processing tools and multiple automatic detection functions, the feature rich software helps the operator easily and accurately detect contraband for the highest throughput and least operator fatigue.

Industry-Leading Operator Training

Rapiscan Systems offers three comprehensive operator training programs: On-system Operator Training Program (OTP); standalone Computer Based Training software (CBT); and live in-person training with expert trainers in a one-to-one or classroom setting. All Rapiscan CBT programs are in full compliance with U.S. Transportation Security Administration (TSA) and European Union (EU) Commission Regulation 185/2010 requirements.

Regulatory Compliance

Rapiscan 626XR image quality performance is in compliance with regulation (EC) No. 300/2008. In addition, Rapiscan 626XR Threat Image Projection (TIP) is in compliance with regulation (EU) No. 185/2010.



www.rapiscansystems.com

Rapiscan[®]
systems
An OSI Systems Company

RAPISCAN 626XR

Physical Specifications

Dimensions:	Length: 3,058 mm (120.4 in.) Width: 1,329 mm (52.3 in.) Height: 1,658 mm (65.3 in.)
Tunnel Size:	950 mm (W) x 650 mm (H) (37.4 x 25.6 in.)
Conveyor Speed:	0.20 m/sec (39.4 ft./min)
Conveyor Load:	165 Kg (364 lbs) evenly distributed
Conveyor Height:	781 mm (30.7 in.)
Approx Weight:	Net: 850 Kg (1,874 lbs)
System Power:	115/230 VAC ±10%, 60/50Hz

Standard X-Ray Generator and Image Performance*

Steel Penetration:	28 mm guaranteed; 30 mm typical
Wire Resolution:	38 AWG guaranteed; 40 AWG typical
Material Separation:	Low Z, Medium Z, High Z to 0.5 Z accuracy
Generator Cooling:	Sealed oil bath with forced air
Anode Voltage:	Operating at 140kV
Tube Current:	0.7 mA
Orientation:	Vertically Upward

High Penetration X-Ray Generator Option and Image Performance*

Steel Penetration:	35 mm guaranteed; 40 mm typical
Wire Resolution:	38 AWG guaranteed; 40 AWG typical
Anode Voltage:	Operating at 160kV
Tube Current:	1.0 mA

Operating Environment

Storage Temperature:	-20°C to 50°C
Operating Temperature:	0°C to 40°C
Relative Humidity:	5 to 95% non-condensing

Health & Safety

Rapiscan Systems' cabinet X-ray products comply with all applicable US FDA and equivalent international regulatory agency requirements, contained in the cabinet X-ray radiation safety performance standard [21 CFR 1020.40] and the general performance standard [21 CFR Part 1010]. Rapiscan Systems certifies each cabinet X-ray product has a maximum radiation emission leakage of less than 1 µSv/hr (0.1 mR/hr) from all external surfaces of the cabinet X-ray system.

Options and Accessories

Target™ / Interactive Target™ (Automatic detection of solid explosives)	Computer Based Operator Training (CBT)
NARCSan™ (Automatic detection of narcotics)	Operator Training Program (OTP)
Density Threshold Alert (DTA)	Manual Scan
Threat Image Projection (TIP)	Operator Pedestal
Threat Image Projection Network (TIPNet)	Foot-mat
NETView™ (Remote network image archive review)	Optical Operator Presence Sensor
NEXLink™ (Advanced network X-ray management automation and link system)	SmartCard Login
Multi-System Alarm Resolution Network Display Station (NDS)	Power Conditioner
Automatic Image Archiving	Conveyor Accessories
Enhanced Image Archiving	Remote Workstation
	High Penetration X-ray Generator
	Universal Printer Support

*Stated performance as measured by Rapiscan Imaging Validation Test Kit.

With continual development of our products Rapiscan Systems reserves the right to amend specifications without notice. Product pictures are for general reference. Please note that due to US laws and regulations, not all Rapiscan products are available for sale in all countries without restriction. Please contact your Rapiscan Systems sales representative for more information.

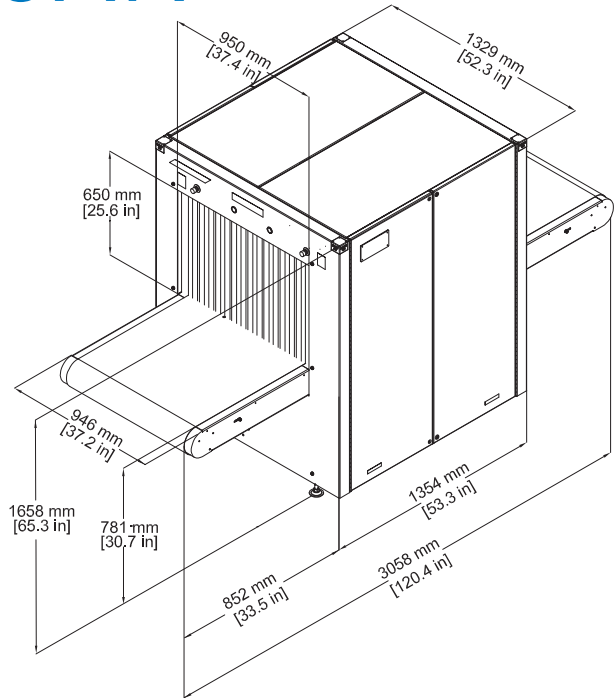

AMERICAS, CARIBBEAN

2805 Columbia Street
Torrance, California 90503
UNITED STATES OF AMERICA
Tel: +1 310-978-1457
Fax: +1 310-349-2491

EUROPE, MIDDLE EAST, AFRICA

X-Ray House
Bonehurst Road
Salfords
Surrey RH1 5GG
UNITED KINGDOM
Tel: +44 (0) 870-7774301
Fax: +44 (0) 870-7774302

ASIA

240 Macpherson Road
#07-01 Pines Industrial Building
Singapore 348574
SINGAPORE
Tel: +65-6846-3511
Fax: +65-6743-9915

EMAIL

sales@rapiscansystems.com

WEB

www.rapiscansystems.com

Rapiscan
systems

An OSI Systems Company



Rapiscan Systems is
ISO 9001:2008 Certified

ONE COMPANY - TOTAL SECURITY

www.rapiscansystems.com